

KSM1JA
INSTRUCTIONS
INSTRUCTIONS
INSTRUCCIONES



KitchenAid®

The KitchenAid® Juicer is designed exclusively for use with all KitchenAid® household Stand Mixers.

For complete information on the use of these Stand Mixers,
please read the instructions that came with your Stand Mixer.

L'extracteur de jus KitchenAid® est conçu pour être utilisé exclusivement avec des batteurs sur socle à usage domestique KitchenAid®. Pour des renseignements complets sur l'utilisation de ces batteurs sur socle, lire le guide d'instructions fourni avec le batteur sur socle.

La juguera KitchenAid® está diseñada exclusivamente para usarse con todas las batidoras domésticas con base KitchenAid®. Para obtener la información completa sobre el uso de estas batidoras con base, lea las instrucciones que vienen con su batidora con base.

WELCOME TO THE WORLD OF KITCHENAID.

We're committed to helping you create a lifetime of delicious meals for family and friends. To help ensure the longevity and performance of your appliance, keep this guide handy. It will empower you with the best way to use and care for your product. Your satisfaction is our #1 goal. Remember to register your product online at www.kitchenaid.com or by mail using the enclosed Product Registration Card.



Join us in the kitchen at www.kitchenaid.com.

TABLE OF CONTENTS

JUICER SAFETY	
Important safeguards.....	4
PARTS AND ACCESSORIES	5
ASSEMBLING THE JUICER	
Assembling the Juicer parts	6
Attaching the Juicer assembly to the Stand Mixer	7
OPERATING THE JUICER	
Making juice.....	8
TIPS FOR GREAT RESULTS	9
RECIPES	9
CARE AND CLEANING	
Cleaning the Juicer.....	14
TROUBLESHOOTING	15
WARRANTY	16

PROOF OF PURCHASE & PRODUCT REGISTRATION

Always keep a copy of the itemized sales receipt showing the date of purchase of your Juicer. Proof of purchase will assure you of in-warranty service. Before you use your Juicer, please fill out and mail your product registration card packed with the unit, or register on-line at www.kitchenaid.com. This card will enable us to contact you in the unlikely event of a product safety notification and assist us in complying with the provisions of the Consumer Product Safety Act. This card does not verify your warranty. Please complete the following for your personal records:

Model Number _____

Serial Number _____

Date Purchased _____

Store Name _____

State of California Proposition 65 Warnings:

WARNING: This product contains one or more chemicals known to the State of California to cause cancer.

WARNING: This product contains one or more chemicals known to the State of California to cause birth defects or other reproductive harm.

IMPORTANT SAFEGUARDS

When using electrical appliances, basic safety precautions should always be followed, including the following:

1. Read all instructions.
2. Always make sure Juicer lid is securely closed before Stand Mixer motor is turned on. Do not remove the lid while Juicer is in operation.
3. Be sure to turn the Stand Mixer OFF (and detach Juicer from Stand Mixer) after each use of the Juicer and before cleaning. Make sure the motor stops completely before disassembling.
4. Do not put your fingers or other objects into the Juicer opening while it is in operation. If food becomes lodged in opening, use pusher or another piece of fruit or vegetable to push it down. Never feed by hand. Always use the pusher. When this method is not possible, turn the motor off and disassemble Juicer to remove the remaining food.
5. Avoid contacting moving parts.
6. The use of attachments not recommended or sold by KitchenAid may cause fire, electric shock, or injury.
7. Do not use outdoors.
8. Close supervision is necessary when any appliance is used by or near children.
9. Do not use the appliance if the rotating auger or rotating parts are damaged. Return appliance to the nearest Authorized Service Facility for examination, repair, or electrical or mechanical adjustment.
10. To protect against risk of electrical shock, do not put mixer in water or other liquid.
11. Do not let the cord hang over the edge of table or counter.
12. Blades are sharp. Handle carefully.
13. Do not open until blade stops.
14. To prevent damage to gear assembly, do not immerse in water or other liquids.
15. This product is designed for household use only.

SAVE THESE INSTRUCTIONS

PARTS AND ACCESSORIES

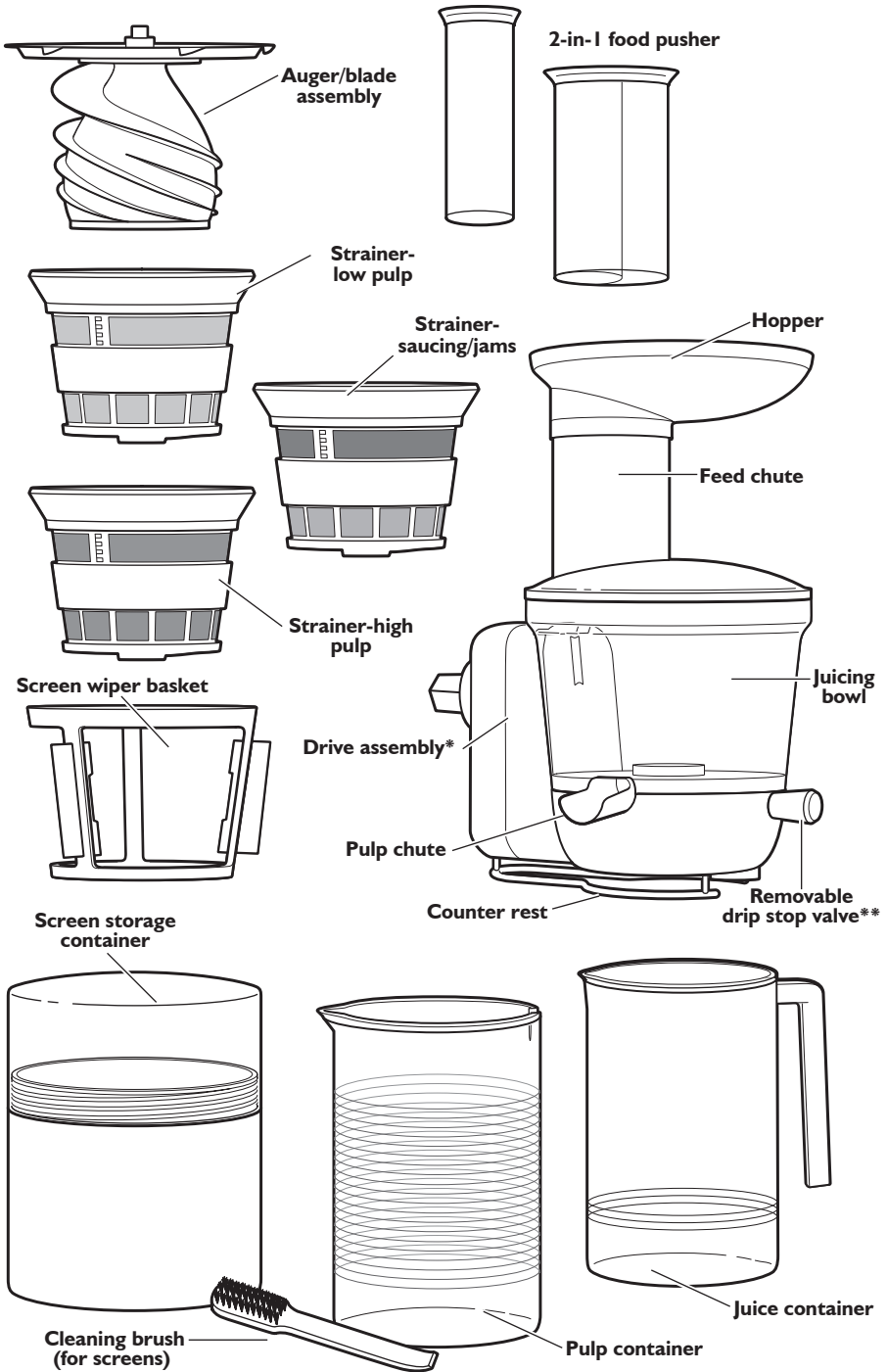

*Wipe clean only. See "Care and cleaning" section for more information.

**Removable drip stop valve can be disassembled into two pieces for better cleaning.

ASSEMBLING THE JUICER

Assembling the Juicer parts

Before First Use

Before using your Juicer for the first time, wipe Juicer parts with a warm damp cloth, then wipe clean with a damp cloth. Do not wash the gear housing assembly. Dry with a soft cloth. See “Care and Cleaning” section.

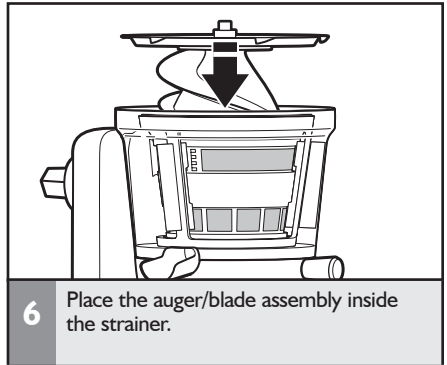
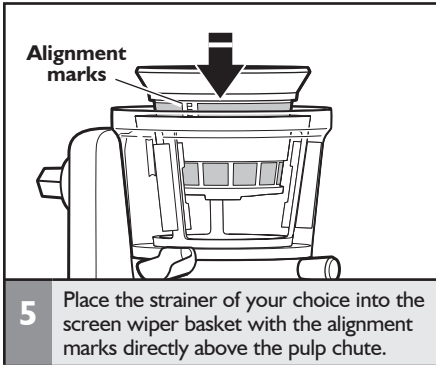
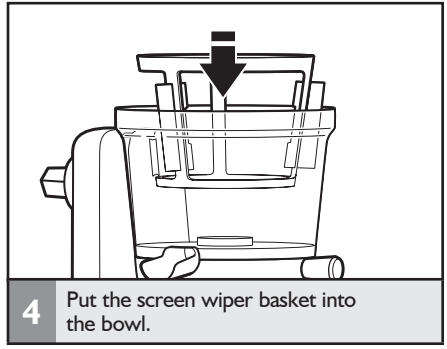
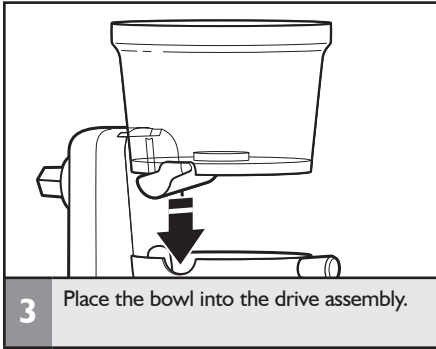
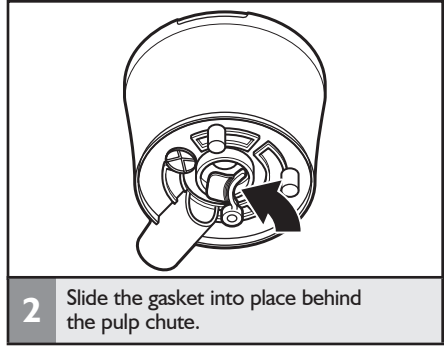
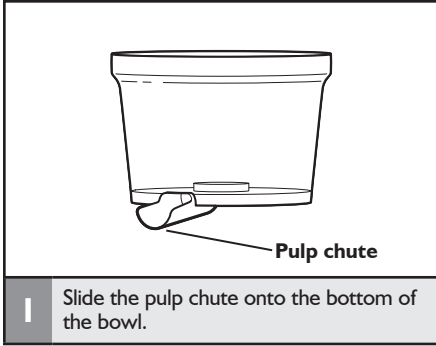

ASSEMBLING THE JUICER

Attaching the Juicer assembly to the Stand Mixer

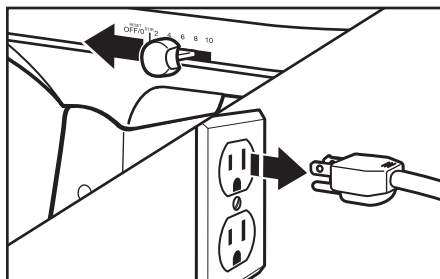

1 Turn Stand Mixer OFF and unplug.



2 **For Stand Mixers with a hinged attachment hub cover:** Flip up to open.
For Stand Mixers with a removable attachment hub cover: Turn the attachment knob counterclockwise to remove attachment hub cover.

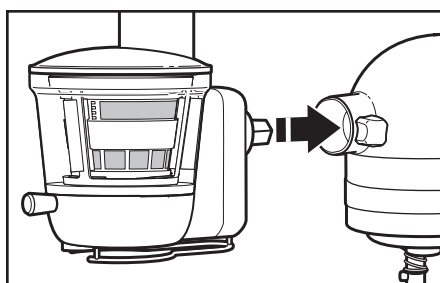

3 Insert the juicer into the attachment hub. Rotate attachment back and forth if necessary. The pin on the attachment housing will fit into the notch of the hub rim when in proper position.

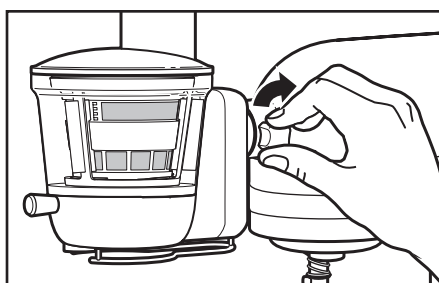

4 Tighten attachment knob until the Juicer attachment is completely secured to Stand Mixer.

ASSEMBLING THE JUICER

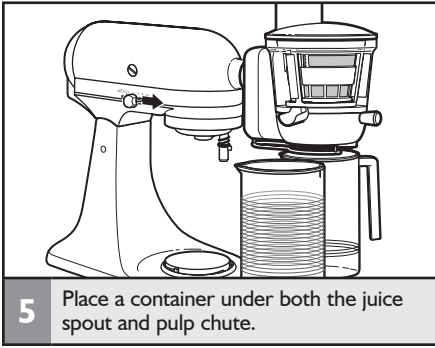

OPERATING THE JUICER

Making juice

IMPORTANT: Large seeds or pits need to be removed prior to juicing to avoid damage to the auger or baskets. This includes fruits such as: nectarines, peaches, mangoes, apricots, plums, cherries, etc.

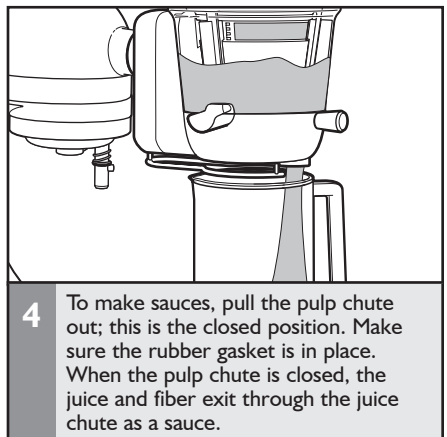
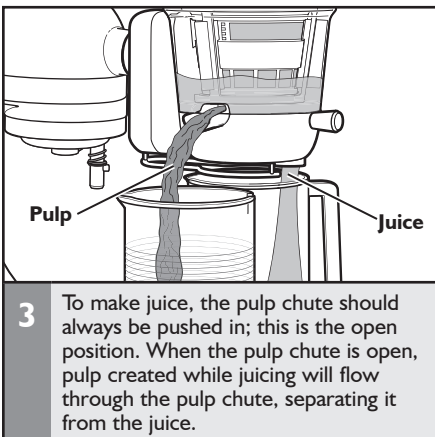
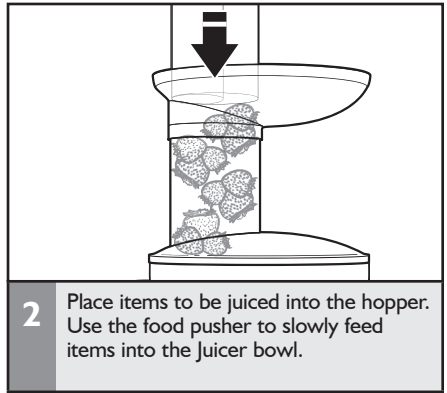
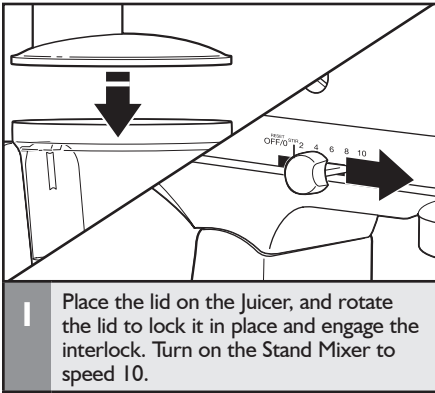

TIPS FOR GREAT RESULTS

- The pulp chute controls how much fibrous material or pulp exits through the juice chute.
 - Pulling the pulp chute out closes the chute, increasing the amount of pulp and fiber for your sauce recipes.
 - Pushing the pulp chute in opens the chute, reducing the amount of pulp for your juice recipes.
- Remember to open the pulp chute when using the high or low pulp screens. Keeping the pulp chute open will prevent the Juicer from locking up.
- The rubber gasket on the bottom of the juicer should be placed properly to reduce loss of juice into the pulp chute. Only remove the rubber gasket if you want juice to flow into the pulp ejector.
- The drip stop should be opened before juicing.
- Large seeds or pits need to be removed prior to juicing to avoid damage to the auger or baskets. This includes fruits such as: nectarines, peaches, mangoes, apricots, plums, cherries, etc.
- Before saucing hard fruits (such as apples), it is recommended that you steam the fruit for 2-3 minutes.

RECIPES

Juices

WINTER FRUIT JUICE

makes 2 cups

1 gala apple

1 d'anjou pear

1 navel orange, peeled if desired

NOTE: When we left the peel on the orange it had a very strong flavor of the peel. The flavor was improved by peeling the orange.

VITAMIN C JUICE

makes 1 cup

6 large strawberries

1 kiwi

1/2 cup peeled and chopped mango

POMEGRANATE APPLE JUICE

makes 1 1/2 cups

1 large gala apple

1 1/2 cups pomegranate seeds

RUBY RED JUICE

makes 1 cup

1/2 cup packed kale

1 small apple

1 beet

3 medium carrots

CARROT GINGER JUICE

makes 1 cup

12 small-medium carrots

1/2 inch piece of ginger (spicy)

CUCUMBER REFRESHER

makes 1 1/2 cups

2 large english cucumbers

1 cup packed fresh spinach

1/2 lemon

NOTE: If you prefer a more sweet juice, add 1 apple.

RECIPES

Spiced Apple Pear Sauce

Makes 4 cups

A twist on a classic, this apple pear sauce is tasty stirred into hot oatmeal or served as a quick weeknight dessert. To ensure a nice texture, make sure to peel the apples before saucing.

2 pounds apples, peeled, cored
and quartered
1 pound pears, cored and quartered
1/4 cup brown sugar
1 teaspoon cinnamon
1/2 teaspoon grated nutmeg
1/4 teaspoon ground cloves

Fit your KitchenAid® Juicer Stand Mixer attachment with the saucing screen and run the apples and pears through the attachment. Pour the apple pear pulp into a saucepan and add the brown sugar, cinnamon, nutmeg and cloves. Simmer until the sauce thickens.

To store, cool to remove temperature and spoon into a container with a tight-fitting lid. It will keep for 2-3 weeks in the fridge.

Pear Caramel Sauce

Yield: 3/4 cup

Taking homemade caramel sauce to another level of flavor with fresh fruit, this pear caramel sauce features fresh pear juice and pear liquor. It'd be wonderful poured over homemade vanilla or cinnamon spice ice cream, and simply sinful drizzled on top of a slice of chocolate cake.

Total Time: 40 minutes

2-3 Comice or Anjou pears, quartered
1/2 cup granulated sugar
pinch cream of tartar
2 tablespoons heavy cream
1 tablespoon butter
1/8 teaspoon salt
1 tablespoon pear liqueur

Juice pears through the low pulp screen. Strain through a fine mesh sieve to remove any large chunks or skins. You should have about 1 cup of juice.

In a small saucepan, cook juice, stirring occasionally, over medium-high heat until thick and butterscotch in color and reduced to 1/4 cup, about 10 minutes. Set aside.

In a small, high-sided saucepan, combine sugar, 2 tablespoons water, and cream of tartar, stirring until sugar has dissolved. When the mixture starts to boil, stop stirring and cover the pan for 2 minutes (the steam buildup will dissolve any stray sugar crystals on the side of the pan). Remove cover and cook, without stirring, for about 8 to 10 minutes or until sugar caramelizes to the color of light beer, swirling the pan as needed to ensure an even color throughout.

Remove from heat and whisk in reduced pear juice, cream, butter, and salt until smooth (mixture will bubble vigorously, so pour carefully to prevent spattering). Stir in pear liqueur and let cool. Caramel sauce will keep, refrigerated in a glass jar or airtight container, for up to 2 weeks. Re-warm prior to serving.

Classic Tomato Sauce

Yield: 3 1/2 to 4 cups

A classic tomato sauce is a staple in every cook's kitchen. The Juicer makes quick work of the otherwise tedious task of seeding and straining the tomatoes, producing a smooth sauce perfect for pasta, pizza, or lasagna. Use the best tomatoes you can find, San Marzano or ripe Roma tomatoes are best. If it is not prime tomato season, canned tomatoes are a better choice.

Total Time: 2 hours

- 3 1/2 pounds fresh Roma tomatoes, halved or 2 (28 ounce) cans whole peeled San Marzano tomatoes
- 1 medium carrot
- 1 tablespoon unsalted butter
- 1 tablespoon extra virgin olive oil
- 1/2 medium onion, finely chopped
- 2 garlic cloves, minced
- 1/2 teaspoon dried oregano
- 1/4 teaspoon salt
- 1/4 teaspoon freshly ground black pepper

Using the sauce screen with pulp control closed, juice tomatoes (along with their juices if using canned tomatoes) and carrot. You should end up with about 6 cups of juice.

In a large saucepan over medium heat, heat olive oil and butter until melted and frothy. Add onion and garlic and sauté until fragrant, about 1 minute. Add tomato juice and oregano and bring to a simmer; cook, stirring occasionally, for 60 to 90 minutes or until sauce has thickened to desired consistency. Season to taste with salt and pepper.

Sauce will keep, refrigerated in airtight container, for up to 5 days, or frozen for up to 3 months.

Vegetable Pulp and Quinoa Cakes

Yield: 16 cakes (5-6 servings)

Put that leftover vegetable pulp to good use with these savory quinoa cakes, packed with flavor and protein. These cakes are great on their own, served with tartar sauce or aioli, or as a veggie burger patty between slider-sized buns. A pulp mix of starchy root vegetables such as carrots, beets, or sweet potatoes, with some added fruit (such as apples) is the best foundation for this recipe. When saving leftover pulp for later use, remove any inedible skins, cores, or seeds from the fruit or vegetables prior to juicing.

Total Time: 45 minutes

- 4 large eggs
- 1 cup quinoa, rinsed and cooked according to package directions (about 3 cups cooked)
- 2 cups vegetable pulp
- 1 cup panko breadcrumbs
- 1 large onion, finely chopped
- 4 garlic cloves, minced
- 1/3 cup packed fresh parsley leaves, chopped
- 1/2 teaspoon kosher salt
- 1/2 teaspoon freshly ground black pepper
- 4 ounces (1/2 cup) goat cheese, crumbled
- 1/3 cup olive oil, divided

Preheat oven to 250°F (121°C).

Whisk eggs in a large mixing bowl. Add quinoa, vegetable pulp, breadcrumbs, onion, garlic, parsley, salt, and pepper and mix until incorporated. Fold in crumbled goat cheese.

Form into 1/2-inch thick patties using 1/4 cup of quinoa mixture per cake. To ensure even sizing, tightly pack into a lightly oiled measuring cup. Arrange on a lightly oiled plate and repeat with remaining quinoa mixture. Refrigerate cakes for 15 minutes before cooking.

Heat 2 tablespoons of olive oil in a large non-stick skillet over medium heat. When oil begins to shimmer, gently lay cakes into the skillet, taking care not to overcrowd the pan. Cook for 4 to 5 minutes per side or until golden brown and crispy. Transfer to a baking sheet and place in the oven to keep warm while you cook the remaining cakes, adding more oil to the pan as needed. Serve warm.

RECIPES

Tofu Carrot Curry

Yield: 4 servings

This light curry is packed with fresh carrot flavor and a hint of tang and spice. Serve with tofu or shredded chicken, rice, bean sprouts, and baby bok choy for a fulfilling meal.

Total Time: 30 minutes

- 1 pound fresh carrots
- 2 medium sweet potatoes (about 3/4 pound), peeled
- 1 inch piece fresh ginger
- 1 garlic clove
- 1 apple, seeded
- 2 teaspoons olive oil
- 1 tablespoon Thai red curry paste
- 3 cups vegetable broth
- 1 cup light coconut milk
- 1 tablespoon lime juice
- 1 tablespoon soy sauce
- 1 pound tofu, cut into cubes

Run carrots and sweet potatoes through the low pulp screen, followed by ginger, garlic, and apple. You should end up with about 1 cup of liquid.

In a saucepan, heat olive oil over medium heat. Add curry paste and stir until fragrant, about 1 minute. Add carrot juice mixture and vegetable broth and bring to a simmer. Stir in coconut milk, lime juice, and soy sauce to taste. Add tofu cubes and cook until heated through. Serve warm.

Strawberry Vanilla Jam

Makes 4 half pints

This is a smooth jam that is always a hit with kids. Do seek out a vanilla bean, as it will give you better flavor than extract.

- 3 pounds strawberries, washed and hulled
- 2 cups granulated sugar
- 1 vanilla bean, split and scraped
- 2 tablespoons powdered pectin
- 1 teaspoon lemon juice

Run the strawberries through the high pulp screen. Measure out four cups of strawberry pulp and pour it into low, wide pan that holds at least 5 quarts.

Whisk the sugar, vanilla bean seeds, and powdered pectin together and add to the strawberry pulp. Place the pan over high heat and bring to a rolling boil.

Cook the jam at a boil, stirring regularly, for 15 to 20 minutes, until it thickens. Add the lemon juice in the last five minutes of cooking. When the jam has reached the set point, it will form a thick layer on the sides of the pan.

Once the jam is finished, funnel it into clean, hot mason jars. Wipe the jar rims and apply new lids and rings. Lower the jars into a stockpot of hot water just off the boil, making sure that the jars fully covered with water. Once the water returns to a boil, set a timer for 10 minutes.

When the time is up, remove the jars from the stockpot and place on a folded kitchen towel to cool. Sealed jars are shelf stable for up to a year.

Pineapple Orange Jelly

Makes 3 half pints

This jelly is a hit with lovers of tropical fruit. If you're finding that you're not getting enough juice from the your pineapple, try running the pulp through the machine a second time.

- 1 large pineapple, peeled, cored and cut into eighths
- 2 navel oranges, peeled
- 2 cups granulated sugar
- 3 tablespoons powdered pectin

Run the pineapple and oranges through the high pulp screen. Measure out four cups of pineapple-orange juice and pour it into low, wide pan that holds at least 5 quarts.

Whisk the sugar and powdered pectin together and add to the pineapple-orange juice. Place the pan over high heat and bring to a rolling boil.

Cook the jam at a boil, stirring regularly, for 15 to 20 minutes, until it thickens. When the jam has reached the set point, it will form a thick layer on the sides of the pan. Another way to judge set it by using a candy or instant read thermometer. When the cooking jelly reaches 221°F (105°), it is done.

Once the jam is finished, funnel it into clean, hot mason jars. Wipe the jar rims and apply new lids and rings. Lower the jars into a stockpot of hot water just off the boil, making sure that the jars fully covered with water. Once the water returns to a boil, set a timer for 10 minutes.

When the time is up, remove the jars from the stockpot and place on a folded kitchen towel to cool. Sealed jars are shelf stable for up to a year.

Cilantro Lime Marinade (low pulp screen)

Makes 2 cups

Taco Tuesday will never be the same once you have this marinade in your culinary toolbox. Use it the next time you're preparing chicken, pork or beef.

- 4 limes
- 1 small yellow onion, peeled and quartered
- 1 cup packed cilantro leaves and stems
- 6 tablespoons extra virgin olive oil
- 1 tablespoon granulated sugar
- 1 teaspoon kosher salt
- 1/2 teaspoon freshly ground black pepper

Fit your KitchenAid® Juicer Stand Mixer attachment with the low pulp screen. Juice two limes, then the onion and cilantro and finish with the remaining limes.

Pour the juice into a jar with a liquid tight lid and add the olive oil, sugar, kosher salt, and pepper. Tighten on the lid and shake to combine. Use as a marinade or vinaigrette.

Store in the refrigerator for up to two weeks.

CARE AND CLEANING

Cleaning the Juicer

IMPORTANT: Never wash or immerse the drive assembly in water. All other parts are top rack dishwasher safe.

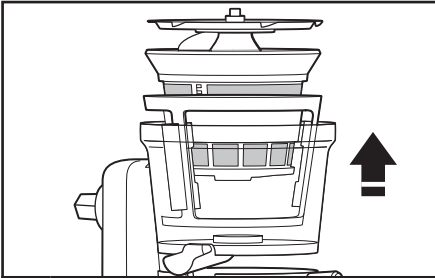

1 **To disassemble:** Remove the lid. Remove the auger. Lift the assembled strainer and screen wiper basket out of the bowl, and separate. Disassemble the pulp chute.

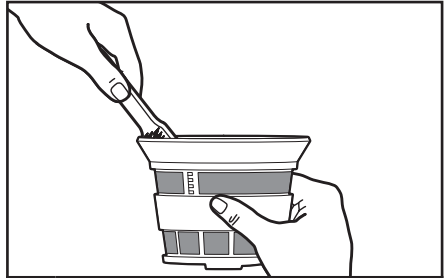

2 Use the brush with warm soapy water to clean out any stuck food or residue in the screens. Never wash or immerse the drive assembly in water. All other parts are dishwasher safe.

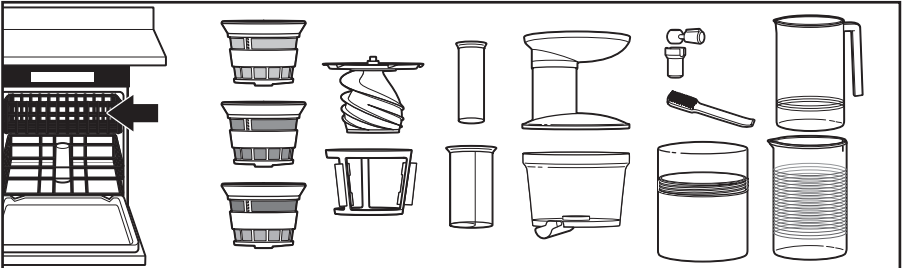

3 Do not wash the drive assembly in the dishwasher. Never wash or immerse the drive assembly in water. All other juicer parts are top rack dishwasher safe.

Juicer does not operate

- Check to see whether the Stand Mixer is plugged into a grounded 3 prong outlet. If it is, check the fuse or circuit breaker on the electrical circuit the Stand Mixer is connected to and make sure the circuit is closed.
- Check to make sure the Juicer attachment was assembled correctly.

If the problem cannot be corrected: See the “Warranty” section. Do not return the Juicer attachment to the retailer; retailers do not provide service. The serial number for service is on the bottom of the drive assembly.

Juice does not flow sufficiently, or is flowing out of the pulp ejector

1. Check the rubber gasket:

- Check to see whether the rubber gasket on the bottom of the juicer is placed properly. If you do want juice to flow into the pulp ejector, make sure the rubber gasket is removed.

2. Make sure you are using fresh fruits or vegetables.

- All carrots, including baby carrots, should only be fed through the small chute one at a time.

Clutch engages

- Check to make sure there are not too many items in the Juicer.
- Make sure any hard seeds are removed.

Makes a squeaking or clicking noise or shakes when making juice

- A squeaking noise is normal. It is the sound of juice being squeezed by the auger.
- Shaking is normal. It is the sign of the motor working properly.
- A clicking noise means the auger has stopped rotating. This is not normal. Turn off the Stand Mixer, then unclog the auger.

WARRANTY

KitchenAid® Juicer Attachment Warranty for the 50 United States, the District of Columbia, Puerto Rico, and Canada

This warranty extends to the purchaser and any succeeding owner for Juicer attachments operated in the 50 United States, the District of Columbia, Puerto Rico, and Canada.

Length of Warranty:

One Year Full Warranty from date of purchase.

KitchenAid Will Pay for Your Choice of:

Hassle-Free Replacement of your Juicer attachment. See the next page for details on how to arrange for service, or call the Customer eXperience Center toll-free at **1-800-541-6390**.

OR

The replacement parts and repair labor costs to correct defects in materials and workmanship. Service must be provided by an Authorized KitchenAid Service Center.



KitchenAid Will Not Pay For:

- A. Repairs when Juicer attachment is used in other than normal single family home use.
- B. Damage resulting from accident, alteration, misuse or abuse.
- C. Any shipping or handling costs to deliver your Juicer attachment to an Authorized Service Center.
- D. Replacement parts or repair labor costs for Juicer attachments operated outside the 50 United States, District of Columbia, Puerto Rico, and Canada.

DISCLAIMER OF IMPLIED WARRANTIES; LIMITATION OF REMEDIES

IMPLIED WARRANTIES, INCLUDING TO THE EXTENT APPLICABLE WARRANTIES OF MERCHANTABILITY OR FITNESS FOR A PARTICULAR PURPOSE, ARE EXCLUDED TO THE EXTENT LEGALLY PERMISSIBLE. ANY IMPLIED WARRANTIES THAT MAY BE IMPOSED BY LAW ARE LIMITED TO ONE YEAR, OR THE SHORTEST PERIOD ALLOWED BY LAW. SOME STATES AND PROVINCES DO NOT ALLOW LIMITATIONS OR EXCLUSIONS ON HOW LONG AN IMPLIED WARRANTY OF MERCHANTABILITY OR FITNESS LASTS, SO THE ABOVE LIMITATIONS OR EXCLUSIONS MAY NOT APPLY TO YOU.

IF THIS PRODUCT FAILS TO WORK AS WARRANTED, CUSTOMER'S SOLE AND EXCLUSIVE REMEDY SHALL BE REPAIR OR REPLACEMENT ACCORDING TO THE TERMS OF THIS LIMITED WARRANTY. KITCHENAID AND KITCHENAID CANADA DO NOT ASSUME ANY RESPONSIBILITY FOR INCIDENTAL OR CONSEQUENTIAL DAMAGES. This warranty gives you specific legal rights and you may also have other rights which vary from state to state or province to province.

Hassle-Free Replacement Warranty – 50 United States, District of Columbia, and Puerto Rico

We're so confident the quality of our products meets the exacting standards of KitchenAid that, if your Juicer attachment should fail within the first year of ownership, KitchenAid will arrange to deliver an identical or comparable replacement to your door free of charge and arrange to have your original Juicer attachment returned to us. Your replacement unit will also be covered by our one year limited warranty. Please follow these instructions to receive this quality service.

If your Juicer attachment should fail within the first year of ownership, simply call our toll-free Customer eXperience Center at **1-800-541-6390** Monday through Friday. Please have your original sales receipt available when you call. Proof of purchase will be required to initiate the claim. Give the consultant your complete shipping address. (No P.O. Box numbers, please.)

When you receive your replacement Juicer attachment, use the carton and packing materials to pack up your original Juicer attachment.

Hassle-Free Replacement Warranty – Canada

We're so confident the quality of our products meets the exacting standards of the KitchenAid brand that, if your Juicer attachment should fail within the first year of ownership, KitchenAid Canada will replace your Juicer attachment with an identical or comparable replacement. Your replacement unit will also be covered by our one year limited warranty. Please follow these instructions to receive this quality service.

If your Juicer attachment should fail within the first year of ownership, take the Juicer attachment or ship collect to an Authorized KitchenAid Service Centre. In the carton

include your name and complete shipping address along with a copy of the proof of purchase (register receipt, credit card slip, etc.). Your replacement Juicer attachment will be returned prepaid and insured. If you are unable to obtain satisfactory service in this manner call our toll-free Customer eXperience Centre at **1-800-807-6777**.

Or write to us at:
Customer eXperience Centre
KitchenAid Canada
200 - 6750 Century Ave.
Mississauga, ON L5N 0B7

Arranging for Service after the Warranty Expires, or Ordering Accessories and Replacement Parts

In the United States and Puerto Rico:

For service information, or to order accessories or replacement parts, call toll-free at **1-800-541-6390** or write to:

Customer eXperience Center,
KitchenAid Small Appliances,
P.O. Box 218, St. Joseph, MI 49085-0218

Outside the United States and Puerto Rico:

Consult your local KitchenAid dealer or the store where you purchased the Juicer attachment for information on how to obtain service.

For service information in Canada:

Call toll-free **1-800-807-6777**.

Or write to:

Customer eXperience Centre
KitchenAid Canada
200 - 6750 Century Ave.
Mississauga, ON L5N 0B7

KitchenAid®
FOR THE WAY IT'S MADE.®

®/™ © 2014 KitchenAid. All rights reserved. The design of the stand mixer is a trademark in the U.S. and elsewhere. Used under license in Canada.

®/™ © 2014 KitchenAid. Tous droits réservés. La forme du batteur sur socle est une marque de commerce aux É.-U. et dans d'autres pays. Utilisé sous licence au Canada.

®/™ © 2014 KitchenAid. Todos los derechos reservados. El diseño de la batidora con base es una marca registrada en EE.UU. y en otras partes. Usada en Canadá bajo licencia.